

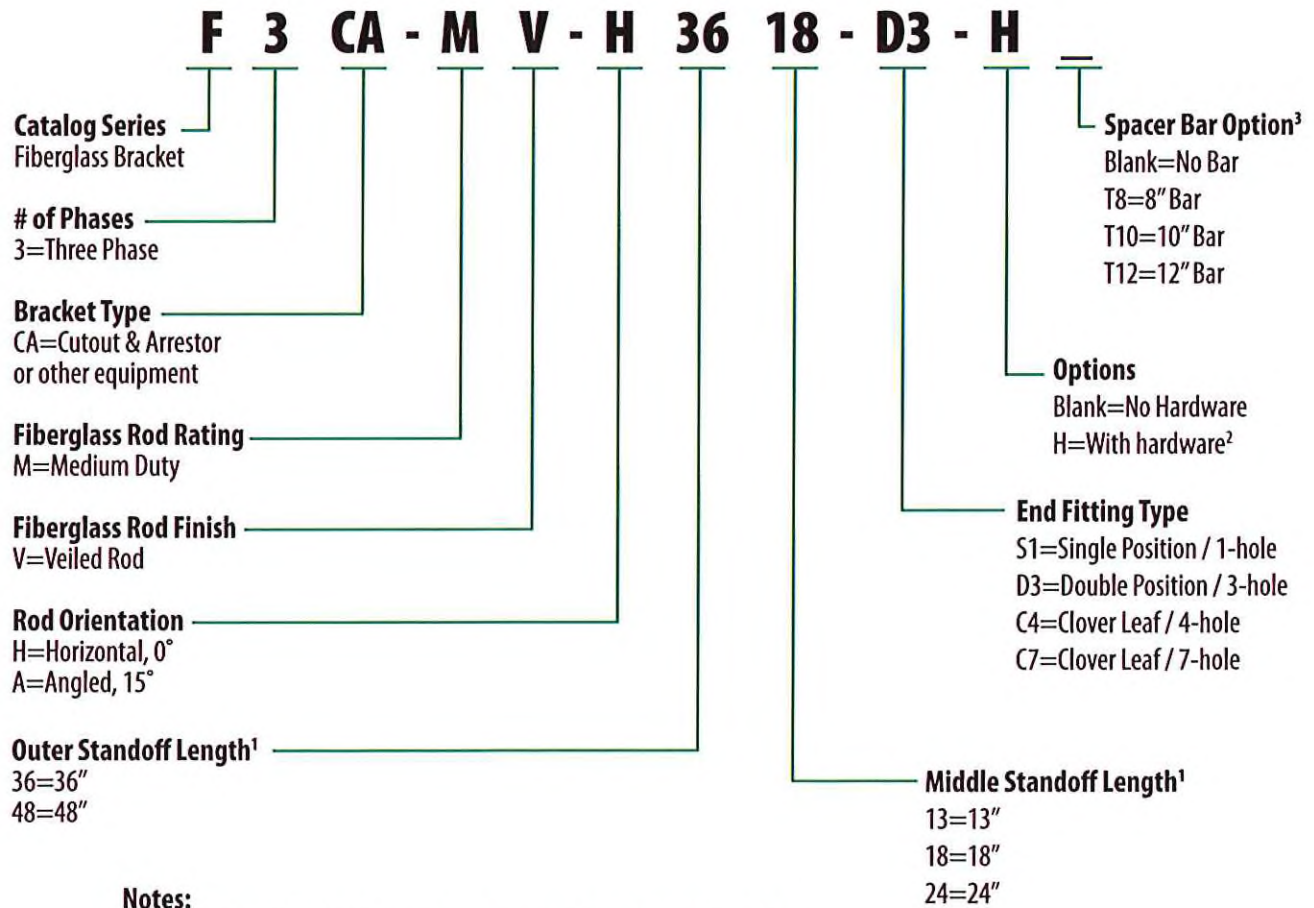

FIBERGLASS EQUIPMENT MOUNTS

Catalog Number System-Three Phase



Notes:

1. Custom lengths available, contact factory or local sales representative.
2. Standard hardware includes captured 1/2" x 2" carriage bolt, 1/2" hex nut, 1/2" lock washer, & 1/2" star washer.
3. Spacer bar option available only with single position (S1) end fitting.

Spacer Bar Option

Cat # Suffix	Cat # to Order Separately w/o Hardware	Cat # to Order Separately w/Hardware	Hole Center Spacing
T8	S1-BAR-T8	S1-BAR-T8-H	8"
T10	S1-BAR-T10	S1-BAR-T10-H	10"
T12	S1-BAR-T12	S1-BAR-T12-H	12"



FIBERGLASS EQUIPMENT MOUNTS

Three Phase/Clover Leaf 4-Hole 15° Mount



Material Specifications

Pole Gain

- 65-45-12 Ductile Iron, hot-dipped galvanized per ASTM A153 (6" to 8" mounting centers)
- Accepts 5/8" pole mounting hardware

End Fitting

- 65-45-12 Ductile Iron, hot-dipped galvanized per ASTM A153

Fiberglass Rod

- 1-1/2" diameter Super-Smooth, proprietary veiled gray polyester rod with added ultraviolet protection

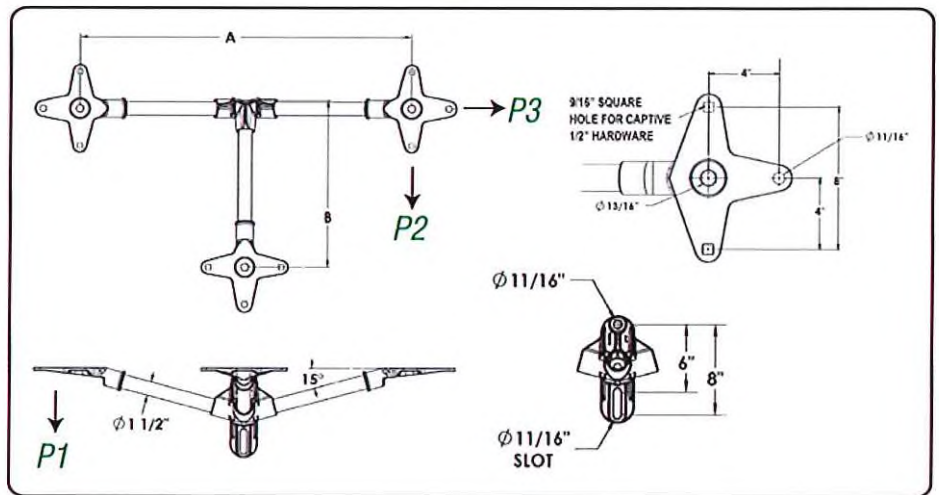

Catalog Name	Rod Diameter	Outside Standoff Length, A ¹	Middle Standoff Length, B ¹	Hardware ²	Ultimate Load			Weight
					P1 (lbs)	P2 (lbs)	P3 (lbs)	
F3CA-MV-A3613-C4	1-1/2"	36"	13"	No	1,200	900	10,000	20.4 lbs.
F3CA-MV-A3613-C4-H	1-1/2"	36"	13"	Yes	1,200	900	10,000	21.7 lbs.
F3CA-MV-A3618-C4	1-1/2"	36"	18"	No	1,200	900	10,000	21.0 lbs.
F3CA-MV-A3618-C4-H	1-1/2"	36"	18"	Yes	1,200	900	10,000	22.3 lbs.
F3CA-MV-A4813-C4	1-1/2"	48"	13"	No	900	700	10,000	22.0 lbs.
F3CA-MV-A4813-C4-H	1-1/2"	48"	13"	Yes	900	700	10,000	23.3 lbs.
F3CA-MV-A4818-C4	1-1/2"	48"	18"	No	900	700	10,000	22.6 lbs.
F3CA-MV-A4818-C4-H	1-1/2"	48"	18"	Yes	900	700	10,000	23.9 lbs.
F3CA-MV-A4824-C4	1-1/2"	48"	24"	No	900	700	10,000	23.4 lbs.
F3CA-MV-A4824-C4-H	1-1/2"	48"	24"	Yes	900	700	10,000	24.7 lbs.

Notes:

1. Custom lengths available, contact factory or local sales representative.
2. Standard hardware includes captured 1/2" x 2" carriage bolt, 1/2" hex nut, 1/2" lock washer, & 1/2" star washer.